

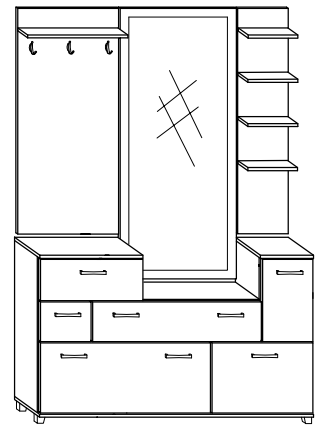

GRAND

→ 130 ↑ 190 ↘ 38



x 33 a	x 3 b	x 14 c	x 14 d	x 8 e	x 8 f
x 4 g	x 2 h	x 4 i	x 10 j	x 2 k	x 3 l
x 3 kpl. m	x 3 o	x 4 (3,5x30) r	x 78 (3,5x16) s	x 100 u	x 1 w
x 1 (300 mm - kpl.) n	x 5 p			 v	

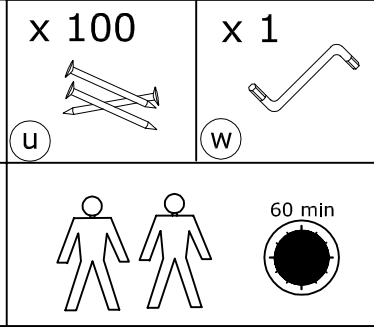

1 - FAZY MONTAŻU

A - OZNACZENIE ELEMENTÓW

a - OZNACZENIE AKCESORIÓW

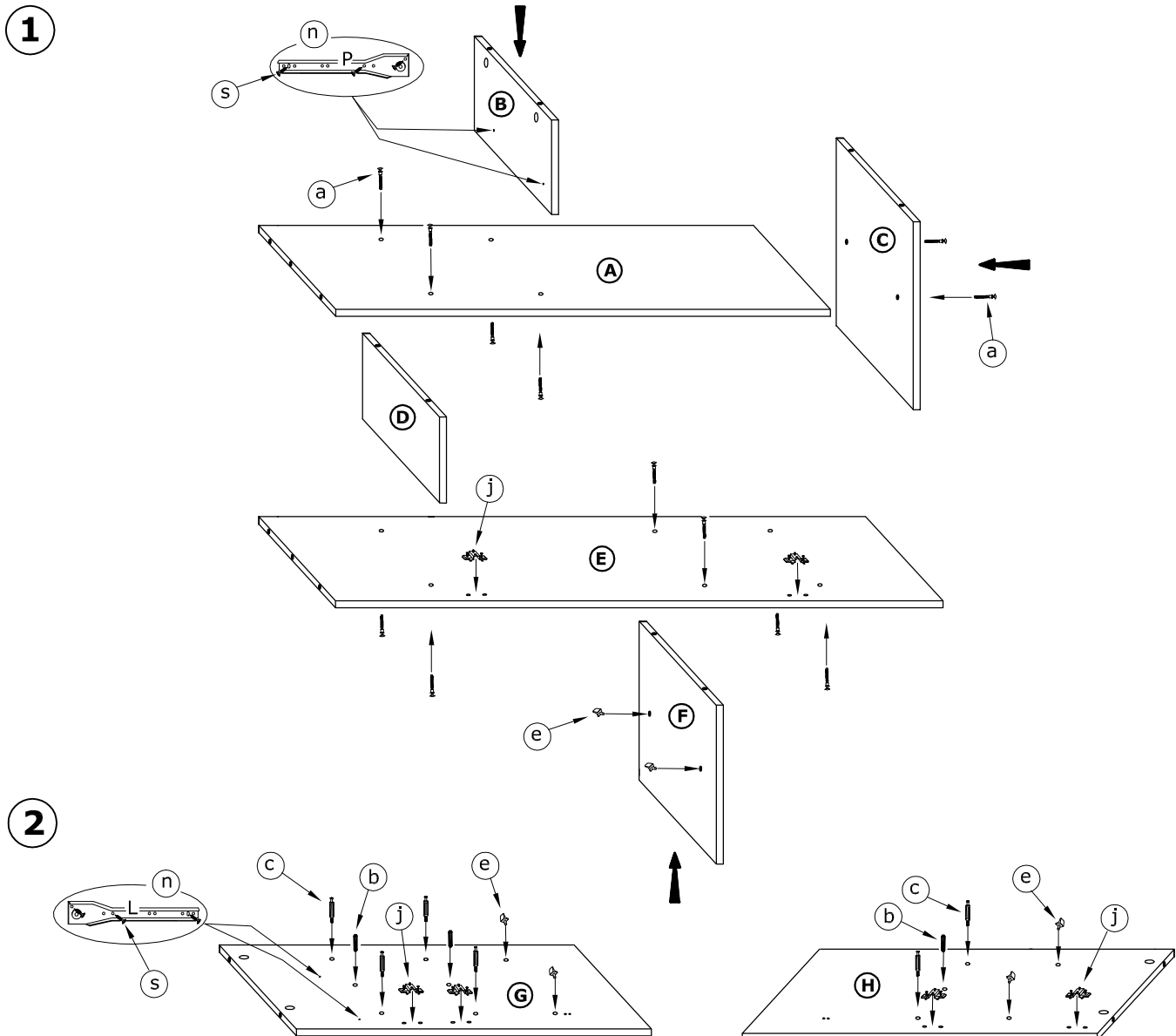

3

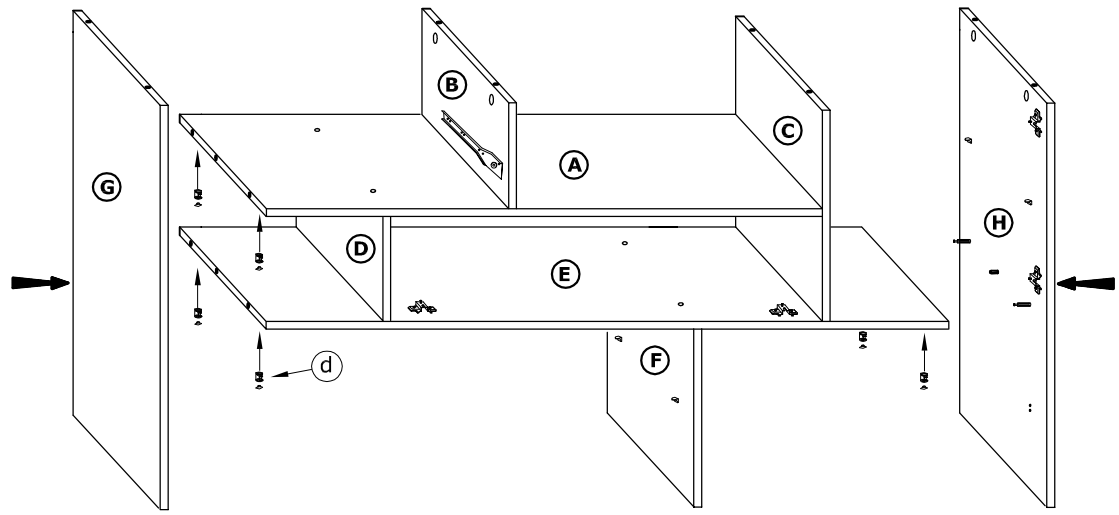

4

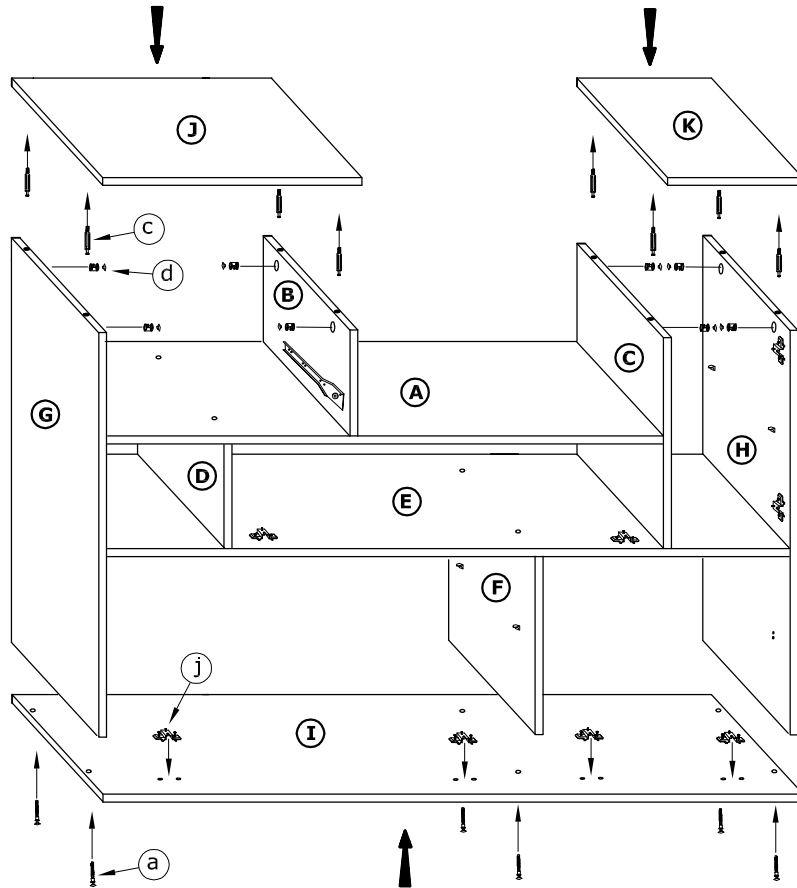

5

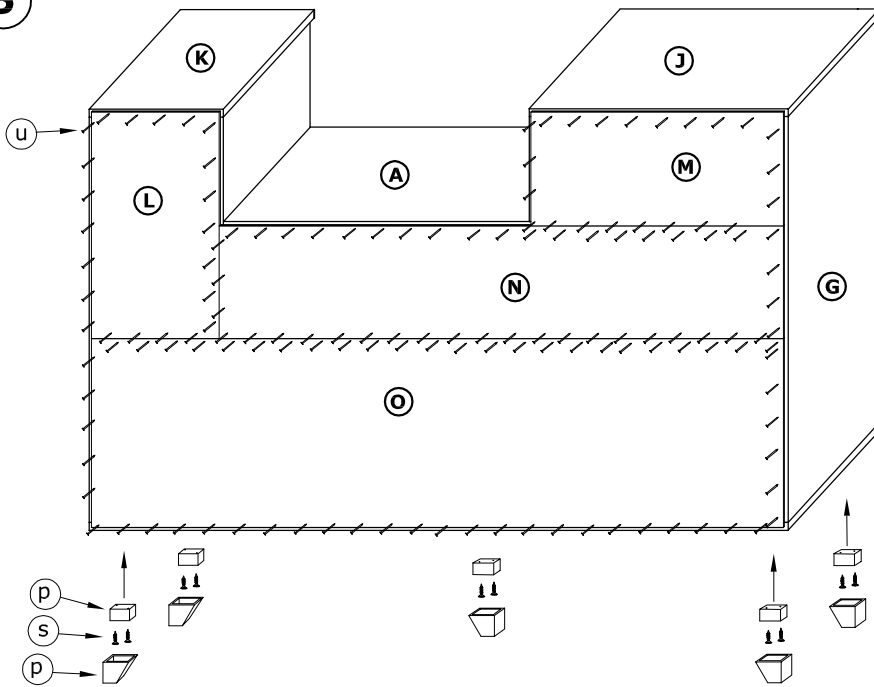

6

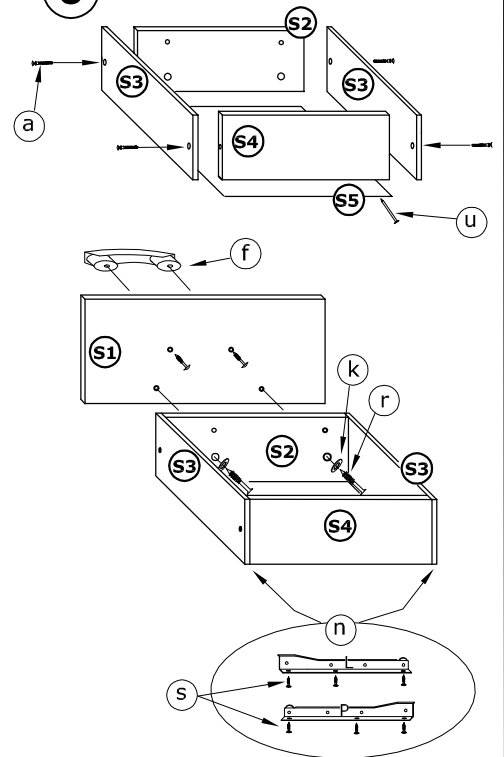

7

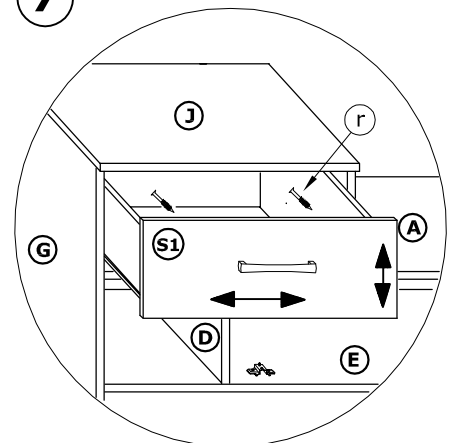

8

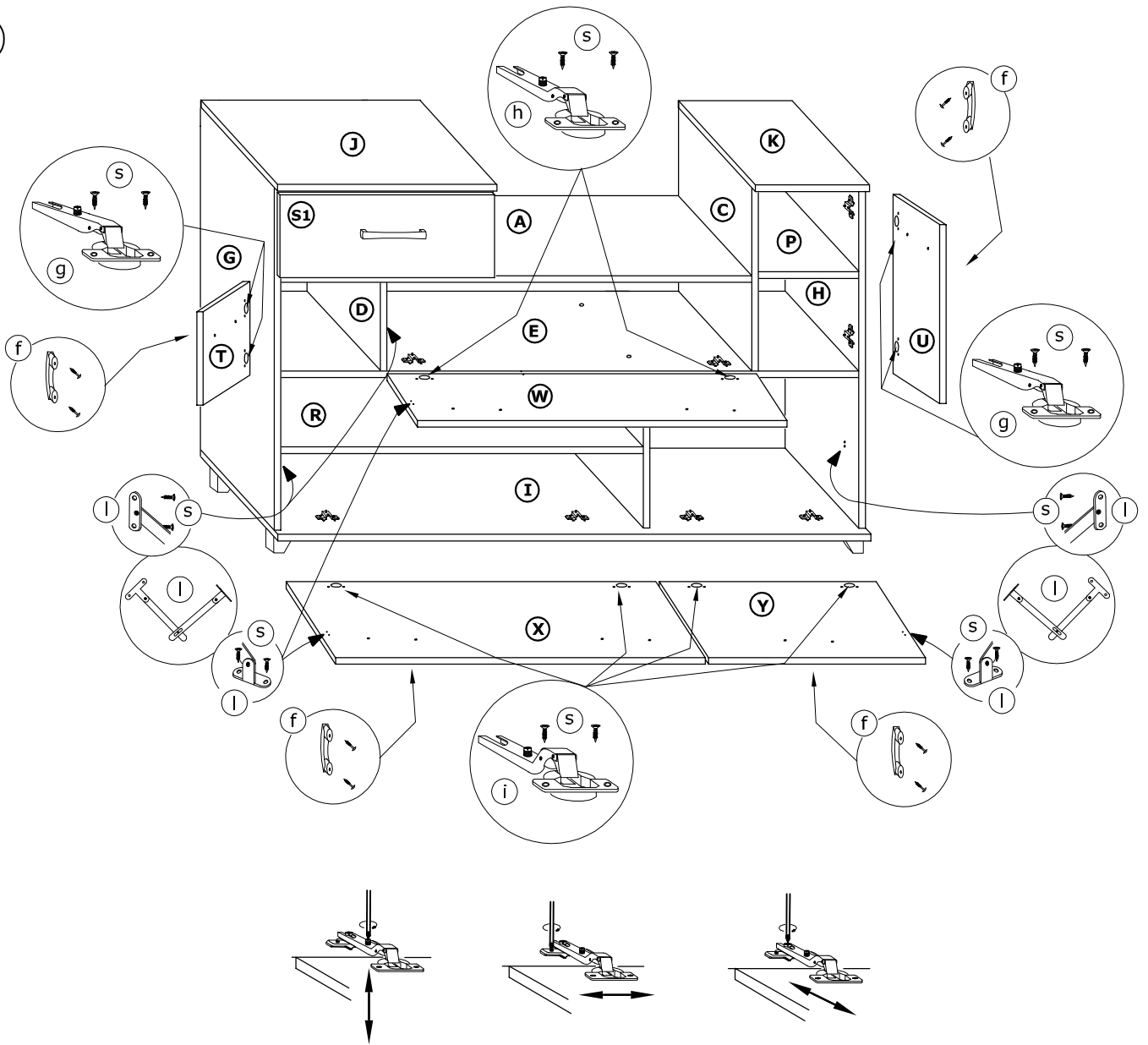

9

